

CANDIDATE GUIDELINES

These candidate guidelines will guide an applicant through the steps necessary to become licensed as a land surveyor in the state of Texas.

Definition of Terms

1. **Surveyor in Training (SIT):** A person certified by the Texas Board of Professional Land Surveying to train under the direction of a designated Registered Professional Land Surveyor (RPLS) in the state of Texas.
2. **Registered Professional Land Surveyor (RPLS):** An individual licensed by the Texas Board of Professional Land Surveying to practice land, boundary, or property surveying. This includes:
 - a. Performing any service or work the adequate performance of which involves applying special knowledge of the principles of geodesy, mathematics, related applied and physical sciences, and relevant laws to the measurement or location of sites, points, lines, angles, elevations, natural features, and existing man-made works in the air, on the earth's surface, within underground workings, and on the beds of bodies of water to determine areas and volume for:
 - i. Locating real property boundaries;
 - ii. Platting and laying out land and subdivisions of land; or
 - iii. Preparing and perpetuating maps, record plats, field note records, easements, and real property descriptions that represent those surveys; and
 - b. consulting, investigating, evaluating, analyzing, planning, providing an expert surveying opinion of testimony, acquiring survey data, preparing technical reports, and mapping to the extent those acts are performed in connection with acts described by this subdivision.
3. **Licensed State Land Surveyor (LSLS):** a surveyor licensed by the Texas Board of Professional Land Surveying to survey land in which the state of Texas or the permanent school fund has an interest or perform other original surveys for the purpose of filing field notes in the General Land Office. This includes:
 - a. determining by survey the location or relocation of original land grant boundaries and corners;
 - b. calculating area and preparing field note descriptions of surveyed and unsurveyed land or land in which the state or the permanent school fund has an interest; and
 - c. preparing maps showing the survey results.

4. **Responsible Charge Time:** The direct control of professional land surveying work performed under the supervision of a RPLS.

SIT Information

In order to become a certified Surveyor in Training in the state of Texas you must be approved by the Board, via the Board's application requirements/processes, and then pass the Fundamentals of Surveying Exam (otherwise known as the SIT Exam).

I. Prerequisites

An applicant must meet the requirements of at least one of the prerequisite sections, as set out by statute, to pass the SIT application process. An applicant will determine which of the following sections they meet:

- a. Section 1071.253 (1): Completion of an approved Bachelor's Degree in Surveying. There are two programs in the state of Texas that grant a surveying degree that have been approved by the Board:

- Bachelors of Science in Geomatics; University of A&M, Corpus Christi, TX
- Bachelors of Science in Industrial Technology with emphasis in Surveying and Mapping; University of Texas, Tyler, TX

Other four-year degree programs offered by institutions around the nation may be accepted as meeting this statutory requirement if they award surveying degrees and are approved by the following accreditation institutions (or their equivalent):

- Accreditation Board for Engineering and Technology (ABET)
- Applied Science Accreditation Commission (ASAC)
- Southern Association of Colleges and Schools (SACS)

- b. Section 1071.253 (2): Completion of a Bachelor's degree, completion of 32 hours of Board approved course work, and completion of at least one year of responsible charge time;
- c. Section 1071.253 (3): Completion of an Associate's Degree in Surveying and completion of at least two years of responsible charge time;
- d. Section 1071.253 (4): Completion of 32 hours of Board approved course work and completion of at least two years of responsible charge time;
- e. Section 1071.253 (5): Proof of graduation from an accredited high school, evidence of self-education in professional surveying, and completion of at least four years of responsible charge time.

An applicant applying under this section must submit to the Board any evidence of self-education, including but not limited to:

- Transcripts conferring completion of any Board approved college course work
- Certificates of completion from seminars, workshops, or courses that are approved by the Board (usually approved as continuing education credits for professionals)
- Any certifications earned pertaining to the practice of surveying

Once an applicant has determined which section they meet, they will submit an application to the Board. All application documents and requirements are available for view and download on the APPLICATION page, under SIT on the Board's website: <http://txls.texas.gov/application-2/>

APPROVED COURSE CHECKLIST

List the course abbreviation and course number. All courses must be conferred by official transcript. If a course that you would like to submit is not in this list, include it at the bottom of the page and attach the course description from your course catalog.

| TOPIC | COURSE | MAX HRS | EQUIVALENT COURSE TITLE | HRS |
|-------------------|------------------------|---------|-------------------------|------------|
| Civil Eng | Eng Problem Solving | 3 | | |
| | Mechanics of Materials | 3 | | |
| | Eng Graphics | 4 | | |
| | Transportation | 4 | | |
| | Land Planning | 4 | | |
| Math | Algebra | 6 | | |
| | Trigonometry | 3 | | |
| | Analytical Geometry | 3 | | |
| | Calculus | 6 | | |
| | Statistics | 6 | | |
| Photogrammetry | | 12 | | |
| Forestry | | 3 | | |
| Land Law | | NO MAX | | |
| Business | Business Law | 6 | | |
| | Management | | | |
| | Economics | | | |
| | Finance | | | |
| Physical Science | Physics | 4 | | |
| | Geology | 4 | | |
| | Geography | 3 | | |
| | Astronomy | 4 | | |
| Computer Science | | 12 | | |
| Cartography | | 3 | | |
| Technical Writing | | 3 | | |
| Ethics | | 3 | | |
| Surveying | | NO MAX | | |
| | | | | TOTAL HRS: |

II. Applying to take the SIT Exam

The completed application, including all required documents, must be received by the Board before the application can be reviewed (use the Application Checklist at the end of this section, or the one included on the application form, to confirm that your entire application has been submitted). There are no deadlines for submission as the exam is offered throughout the year at testing centers around the nation.

An applicant is required to:

- a. Complete each question on the Surveyor in Training Application Form. Include with the application a passport-type picture of the applicant and a check or money order, made payable to the Texas Board of Professional Land Surveying, in the amount of the required fee. PLEASE NOTE: On section three of the application, please enter information that will correspond to your Reference Waivers (i.e.: same dates, times, names of surveyors/surveying firms, etc.)
- b. Complete the Character Reputation and Fitness Form
- c. Submit an official college transcript and the Approved Course Checklist. Only transcripts in unopened envelopes from the institution are considered official. PLEASE NOTE: If you have earned a degree from a foreign institution, or an institution that is not accredited by one of the Board approved accreditation institutions, the curriculum must be translated by a Board approved analysis agency. Please contact the Board office for the list of agencies.
- d. Submit three Reference Waiver Forms completed by a professional land surveyor that can attest to your responsible charge time.

All fees are non-refundable. The applicant will be notified of the status of their application by mail. If required by the Board, the applicant will be allowed to make changes to their application. If you fail to complete an application, or fail to attempt the SIT Exam, within a year of original submission, the application will expire requiring the applicant to begin the process again.

A Department of Public Safety background check for the applicant will be obtained by the agency as part of the application process. The Board may request from the applicant a written explanation of anything found on the background check.

SIT Application Checklist

- I have read the Candidate Guidelines and familiarized myself with the Act and Rules.
- I have completed the education and/or experience required by the section of the Act under which I am applying.
- All sections of my application are complete and my signature is included on the last page.
- My “passport-type” photo is signed and attached to the front page of my application.
- I have submitted three (3) Reference Waivers completed by the three RPLS that know my work experience best.
- My Character, Reputation, and Fitness Form has been completed and submitted.
- I have submitted my official transcripts (when applicable) that support the completion of the course work that I want the Board to consider.
- I have completed and submitted the Course Checklist (when applicable).
- A cashier’s check, or money order, for the required application fee is included with this application

III. NCEES

NCEES is a national nonprofit organization dedicated to advancing professional licensure for engineers and surveyors.

All applicants are required to register with NCEES and pay an exam fee for each exam that they take. This can be done at any time. It is not necessary for an applicant to wait until they are approved by the Board to take the exam to register with NCEES. However, an applicant will not be permitted to select an exam time/location until their application has been approved by the Board.

The SIT Exam, or the Fundamentals of Surveying Exam, is required by Texas to gain licensure as a professional surveyor. The exam is computer based and is offered by NCEES for two month periods, four times a year, at testing centers around the nation. For more information about the exam, how it is developed, study materials, exam protocol, permitted calculators, etc., please visit <http://ncees.org/>

Once an application is approved by the Board, NCEES is notified. NCEES then notifies the applicant via email that they are permitted to select an exam time/location.

IV. Passing/Failing the Exam

NCEES will provide exam results to the applicant as well as the Board. If the applicant passes the exam, the Board will mail them a packet, including a confirmation letter, a certificate, and the RPLS Designation Form. The RPLS Designation Form must be completed by the applicant and returned to the Board office. The date that the applicant passes the SIT Exam will be the date that their experience as a SIT begins.

If the applicant wants to take the exam again after failing they must submit the Request for Authorization Form to the Board in order to be authorized through NCEES (found on the Board's website on the APPLICATION page under SIT). Applicants can take the exam three times before being required to wait one year before their next attempt. During this year, applicants are encouraged to acquire further education and experience in the field of surveying.

The Surveyor in Training certification is valid for eight years. If a SIT would like to extend their certification past the eight years, they are required to submit the appropriate application (this application is found under SIT on the SIT RENEWAL page), submit the required fee, and provide proof that they have completed 32 hours of Board approved course work or Board approved continuing education since the date they were certified. If approved, this application will extend the certification for one year. Each year thereafter, the SIT must submit the extension application, fee, and include proof that they have completed at least eight hours of Board approved course work or Board approved continuing education since their last extension.

An individual holding a current certification as a Surveyor in Training issued by another state is able to transfer that certification to Texas. To transfer a certification and obtain an official SIT certificate, an individual must submit the appropriate application (this application is found on the APPLICATION page under SIT and is entitled "SIT Certification Application"), the required fee, and a license verification from the state issuing the certification. If an individual's certification was granted more than eight years prior to the submission of the transfer application, and the applicant is not able to present proof that the certification has been renewed in that state and is in fact current, the certification is not eligible for transfer. If a certification is deemed not eligible for transfer the individual will then be required to apply for and take the SIT Exam in order to gain certification.

TEXAS "SURVEYOR IN TRAINING" CERTIFICATION PROCESS

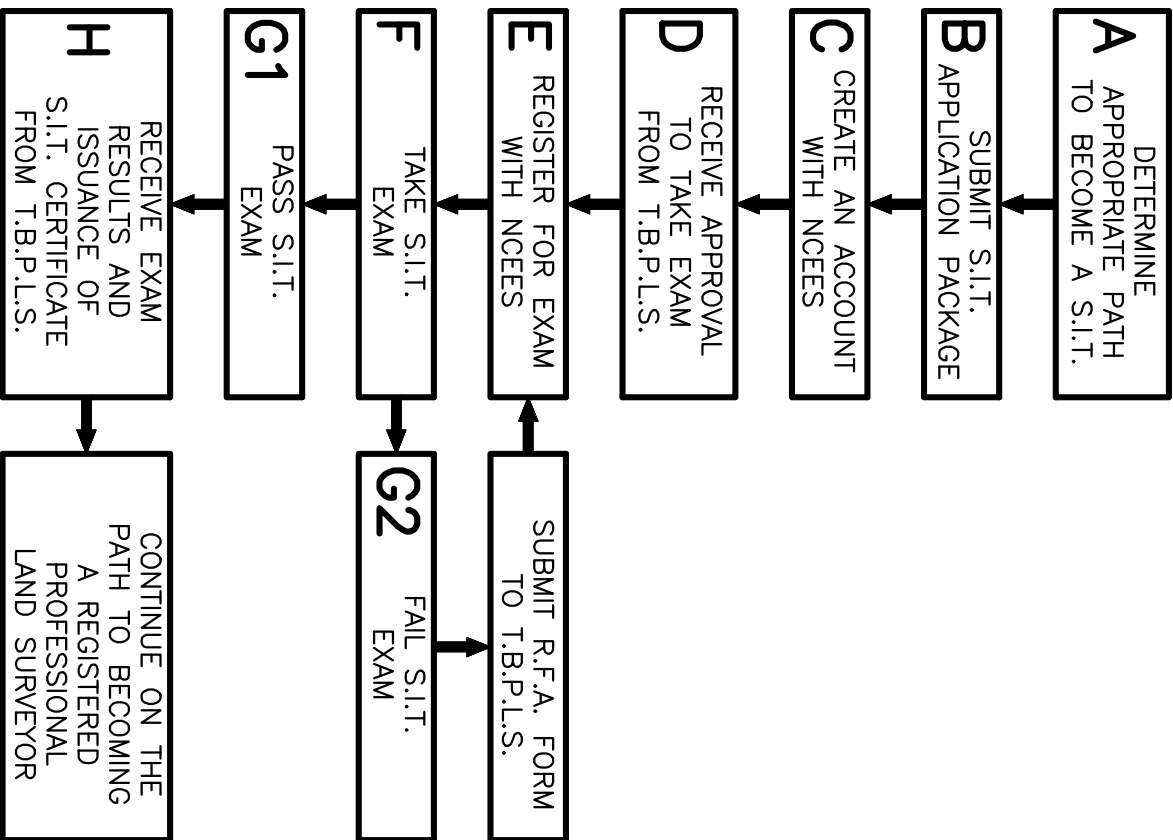

- A. There are five different paths to qualify to take the S.I.T. exam:
1. hold a Bachelor of Science in surveying;
 2. hold a Bachelor's degree with 32 hours in civil engineering, land surveying, math, photogrammetry, forestry, land law or the physical sciences and one year of experience working under a RPLS;
 3. hold an Associate's degree in surveying and have two years of experience working under a RPLS;
 4. have 32 hours in land surveying courses and two years of experience working under a RPLS; or
 5. graduated from high school, have four years of experience working under an RPLS, and can prove you are self-educated in land surveying.

- B. Submit the S.I.T. application package to the T.B.P.L.S. which includes:
1. the S.I.T. application form
 2. completed Character, Reputation and Fitness Information form
 3. a minimum of three (3) Reference Forms
 4. official college transcripts (unopened)
 5. required application fee

- C. All applicants must create an account with the NCEES to be eligible to take the exam. Visit their website at NCEES.org to complete this step.

- D. The T.B.P.L.S. will review the application package to verify qualifications and if approved will inform the applicant. Applicant will be instructed to proceed with exam registration with NCEES on their website.

- E. On the NCEES website you will register for the exam, pay the exam administration fee and select your testing time and location.

- F. Take the exam at the Computer Based Testing Facility of your choice. NCEES will provide all instructions for the exam.

- G. Following the exam, you will be notified by NCEES of the exam results within 7 to 10 business days.

- If you receive:
1. a passing grade, you will continue to step H.
 2. a failing grade, you may submit a Request For Authorization (R.F.A.) to the T.B.P.L.S. in order to re-take the exam and return to Step E.

- H. The T.B.P.L.S. will receive the exam results from NCEES and will issue a Surveyor In Training Certificate.

NOTE: all forms can be found on the T.B.P.L.S. website www.txls.texas.gov

RPLS Information

In order to become licensed as a Registered Professional Land Surveyor, or RPLS, in the state of Texas, you must be a SIT for two years or be licensed as a professional in another state. In addition, all individuals sitting for either the RPLS Exam, or the Reciprocal Exam, must hold a Bachelor's degree and have completed the 32 hours of Board approved course work.

I. Prerequisites

a. Degree Requirement

All individuals pursuing licensure as a professional land surveyor in the state of Texas are required to have earned a Bachelor's degree. Any degree will meet this requirement when supplemented by 32 hours of Board approved collegiate course work. This requirement is waived for those individuals that have been licensed by another state before January, 2003.

b. SIT Experience

All applicants that would like to take the RPLS Exam need to have two years of responsible charge time working under their designated RPLS. During this time the applicant is required to accrue 4000 hours of experience in five fields. Each field has its own Compliance Verification Form (found on the Board's website on the APPLICATION page under RPLS) that is completed by the applicant, signed by the designated RPLS, and submitted to the Board. The fields of experience are:

- i. Research
- ii. Legal Principles/Boundary Reconciliations and Deed Sketches
- iii. Computations/Traverse Accuracy Analysis
- iv. Documentation/Descriptions/Monumentation/Preparing Final Surveys
- v. Field Experience

II. Applying to take the RPLS Exam

The completed application, including all required documents, must be received by the Board before the application can be reviewed (use the Application Checklist at the end of this section, or the one included on the application form, to confirm that your full application has been submitted).

An applicant is required to:

- a. Complete each question on the RPLS Application Form. Include with the application a passport-type picture of the applicant (this is required even if you have submitted a picture with the SIT application) and a check or

money order, made payable to the Texas Board of Professional Land Surveying, in the amount of the required fee.

- b. Complete the Character Reputation and Fitness Form
- c. Submit an official college transcript and the Approved Course Checklist. Only transcripts in unopened envelopes from the institution are considered official. These transcripts must confer the completion of a Bachelor's degree and 32 hours of Board approved course work. If you have submitted your transcripts with your SIT application, they show the completion of the requirements, and nothing has changed, you are not required to resubmit. PLEASE NOTE: If you have earned a degree from a foreign institution, or an institution that is not accredited by one of the Board approved accreditation institutions, the curriculum must be translated by a Board approved analysis agency. Please contact the Board office for the list of agencies.
- d. Complete, and have your designated RPLS sign, all five Compliance Verification Forms. Five must be submitted for every RPLS you have designated and who has overseen your responsible charge time.
- e. Two sample boundary surveys, accompanied by a list of the documents used to construct them, must be submitted. These surveys must meet the minimum standards set by the Board (standards are listed in the Board rules) and can be constructed for the purpose of the application. The surveys can be based on fictional lands if needed. One survey must be RURAL (metes and bounds), and include a separate metes and bounds description, and the other must be URBAN (lot and block). Each survey must be created by and signed by the applicant. Neither survey should be sealed.

It is only necessary to apply to the Board, and pay the application fee, one time. All fees are non-refundable. Only applications completed by the deadline of January 15 (deadline for the April exam) or July 15 (deadline for the October exam) will be reviewed by the Board in preparation for the ensuing exam. The applicant will be notified of the status of their application after the deadline and the Board will allow one more opportunity for the applicant to submit supplementary changes to the application (if necessary). If you fail to complete an application, or to take the RPLS Exam, within a year of original submission, the application will expire requiring the applicant to begin the process again.

A Department of Public Safety background check for the applicant will be obtained by the agency as part of the application process. The Board may request from the applicant a written explanation of anything found on the background check.

RPLS Application Checklist

- I have read the Candidate Guidelines and familiarized myself with the Act and Rules.
- I have completed the education and/or experience required by the section of the Act under which I am applying.
- All sections of my application are complete and my signature is included on the last page.
- My “passport-type” photo is signed and attached to the front page of my application.
- I have completed all five Compliance Verification Forms, had them signed by my designated RPLS, and the hours listed on the forms add up to 4000.
- My Character, Reputation, and Fitness Form has been completed and sent to the Board office.
- I have submitted two sample boundary surveys; one rural (metes and bounds) and one urban (lot and block); that I have signed. I have included a list of all documents I used to construct the samples.
- My designated RPLS has reviewed my sample surveys prior to their submission.
- I have submitted my official transcripts that support the completion of my Bachelor’s degree and my 32 hours of Board approved course work.
- I have completed and submitted the Approved Course Check List.
- A cashier’s check, or money order, for the required application fee is included with this application.

III. RPLS Exam

Once an applicant has been approved by the Board, the applicant is required to submit the exam fee in order to take the exam (exam dates can be found on the Board’s website by accessing the drop-down menu under RPLS, accessing the EXAMINATION page, and clicking on EXAM DATES). The applicant will receive confirmation of their approval and exam fee payment submission form in the mail.

a. Exam Fee

The exam fee must be submitted as a check or money order made payable to the Texas Board of Professional Land Surveyors. Individuals that fail to pay this fee will not be allowed into the testing area. An exam fee must be paid each time an applicant sits for the exam. If the applicant notifies the Board 10 days or more before the exam date that they are not able to attend, the exam fee can be applied to the next scheduled exam. This can only be done once per exam fee.

b. Exam Development

The scope of the RPLS Exam will cover, but is not limited to, the following elements:

- i. The Professional Land Surveying Practices Act
- ii. The Board’s General Rules of Procedures and Practices
- iii. Reading and understanding of court opinions
- iv. Preparation of metes and bounds descriptions
- v. Surveying terms

- vi. Conflicting elements of land descriptions
- vii. Aliquot Descriptions
- viii. The Texas Natural Resource Code
 - ix. Adverse Possession
 - x. Specifics concerning original land grants
 - xi. Determining seniority of surveys and the retracement of original survey lines
 - xii. Determining seniority of tracts/deeds and retracement/location of the lines thereof
- xiii. Application of the dignity of calls
- xiv. Recognition of ambiguities, conflicts, and other discrepancies
 - xv. Partitioning of real property
 - xvi. Simultaneous conveyance

Study materials, including court cases and a sample analytical problem are posted on the Board's website at <http://txls.texas.gov/study-materials/>. The Board creates each exam in-house with the help of the Examination Committees. The contents of each exam vary and are confidential.

c. Exam Protocol

An applicant wanting to take the RPLS Exam must have a valid federal or state issued photo I.D. Individuals with expired, fake, or foreign I.D. will not be allowed into the testing area.

Each test taker is allowed to bring only the permissible items into the testing area. No devices (other than the approved calculators), paper of any kind, weapons, or hats will be permitted. All items being brought into the testing area must be in a clear plastic bag. No other bags are permitted. Any prohibited items found in the possession of a test taker will result in their disqualification from the exam and their removal from the testing area. Food and drink are permitted but must stay on the floor at all times.

The approved calculator models are:

- i. Hewlett-Packard: HP 33s and HP 35s
- ii. Casio: All fx-115 models
- iii. Texas Instruments; All TI-30X and TI-36X models

The RPLS Exam is a closed book, eight hour exam. Number two pencils must be used on the answer sheet. No discussion between test takers is permitted in the testing area. The exam is designed to test for competency. Scores are calculated by summing the number of correct responses within a section. Credit is awarded for correct responses while no credit is awarded for incorrect responses. Candidates should answer all questions

on the exam, as there is no penalty for guessing. The exam is multiple-choice, with five choices for each question.

d. Exam Results

Each exam will be graded by machine. The Board does not utilize fixed-percentage passing scores or “grade on the curve” methods. Once all grades are recorded and analysis of the exam’s performance is complete, the results will be presented to the Board at the ensuing Board meeting. Only after the Board has voted to ratify licensure for the examinees with passing grades will the results be released to the public. Result letters will then be mailed to the examinees.

i. Passing the exam

If an applicant passes the RPLS Exam, they are issued a license to practice professional land surveying in the state of Texas. At that time the new licensee must pay the registration fee in order for their license number to be released. They must also file an impression of their newly created Texas seal with the Board.

ii. Failing the exam

If an applicant fails the exam, and wishes to take it again, they are required to submit a completed Update Application and exam fee. Individuals are allowed three attempts to pass the exam before they are required to wait a year and acquire further experience and education.

IV. Reciprocal Applicants

An individual may gain licensure as a professional land surveyor in the state of Texas if they hold a current license as a professional land surveyor in another state and pass the Board’s Reciprocal Exam.

a. Prerequisites

In order to be approved to sit for the Reciprocal Exam an individual must:

- i. be currently licensed as a professional land surveyor in another state (the Board will review any disciplinary history an applicant has with another state Board at the time of application. More information regarding disciplinary situations may be requested from the applicant);
- ii. have passed the Fundamentals of Surveying Exam; and
- iii. have completed a Bachelor’s degree

b. Applying for the Reciprocal Exam

An applicant is required to:

- i. Complete each question on the Reciprocal Application Form. Include with the application a passport-type picture of the applicant

and a check or money order, made payable to the Texas Board of Professional Land Surveying, in the amount of the required application fee.

- ii. Complete the Character Reputation and Fitness Form
- iii. Submit an official college transcript conferring completion of a Bachelor's degree. This requirement is waived for those individuals that hold a surveying license granted by another state before January 2003.
- iv. Two sample boundary surveys, accompanied by a list of the documents used to construct them, must be submitted. These surveys must meet the minimum standards set by the Board (all standards are listed in the Board rules) and can be constructed for the purpose of the application. The surveys do not have to be based on real-life documents. One survey must be URBAN (lot and block) and the other must be RURAL (metes and bounds). A separate metes and bounds description must be submitted for the rural survey as well. Both surveys, metes and bounds description, and list of documents must be submitted in hard copy and electronic format. Each survey must be created by the applicant and must be signed by the applicant. Neither survey should be sealed.
- v. Submit three Reference Waiver Forms completed by three professional land surveyors that can attest to the applicants experience in the field and over all character.
- vi. A License Verification Form must be completed by each state Board in which the applicant holds a professional land surveying license. Some states charge a fee for this verification.

It is only necessary to apply to the Board, and pay the application fee, one time. All fees are non-refundable. Only applications completed by the deadline of January 15 (deadline for the April exam) or July 15 (deadline for the October exam) will be reviewed by the Board in preparation for the ensuing exam. The applicant will be notified of the status of their application after it has been reviewed. The Board will allow one opportunity for the applicant to submit supplementary changes to the application, if necessary. If the applicant fails to complete an application, or to take the Reciprocal Exam, within a year of original submission, the application will expire requiring the applicant to begin the process again.

A Department of Public Safety background check for the applicant will be obtained by the agency as part of the application process. The Board may request from the applicant a written explanation of anything found on the background check.

c. Reciprocal Exam

The Reciprocal Exam is a four hour exam dealing with the particulars of surveying Texas lands. This state-specific exam is comprised of legal subject

matter specific to Texas and includes one analytical problem. Some of the legal principles present on the exam are:

- i. The Professional Land Surveying Practices Act
- ii. The Board's General Rules of Procedures and Practices
- iii. Adverse Possession/Statute of Limitations
- iv. Texas Coordinate System
- v. Platting requirements
- vi. Disposition of Public Domain (Spanish land grants, Spanish Definitions, Railroad blocks, etc.)
- vii. Riparian/Littoral rights
- viii. Deceptive Trade Practices Act
- ix. Excess and vacancies
- x. Units of measure
- xi. The General Land Office
- xii. City/County/State Records
- xiii. Historical facts
- xiv. Disposition of the public domain
- xv. Evidence
- xvi. Case Law/Legal definitions

There is no exam fee required of a reciprocal applicant the first time they take the exam.

Please see the RPLS Testing Protocol section of these candidate Guidelines for more exam information.

d. Exam Results

Each exam will be graded by machine. The Board does not utilize fixed-percentage passing scores or "grade on the curve" methods. Once all grades are recorded and analysis of the exam's performance is complete, the results will be presented to the Board at the ensuing Board meeting. Only after the Board has voted to ratify licensure for the examinees with passing grades will the results be released to the public. Result letters will then be mailed to the examinees.

i. Passing the exam

If an applicant passes the Reciprocal Exam, they are issued a license to practice professional land surveying in the state of Texas. At that time the new licensee must pay the registration fee in order for their

license number to be released. They must also file an impression of their newly created Texas seal with the Board.

ii. Failing the exam

If an applicant fails the exam, and wishes to take it again, they are required to complete and submit an Update Application and exam fee. Individuals are permitted to take the exam three times before they are required to wait a year and acquire further experience and education.

TEXAS “REGISTERED PROFESSIONAL LAND SURVEYOR” REGISTRATION PROCESS

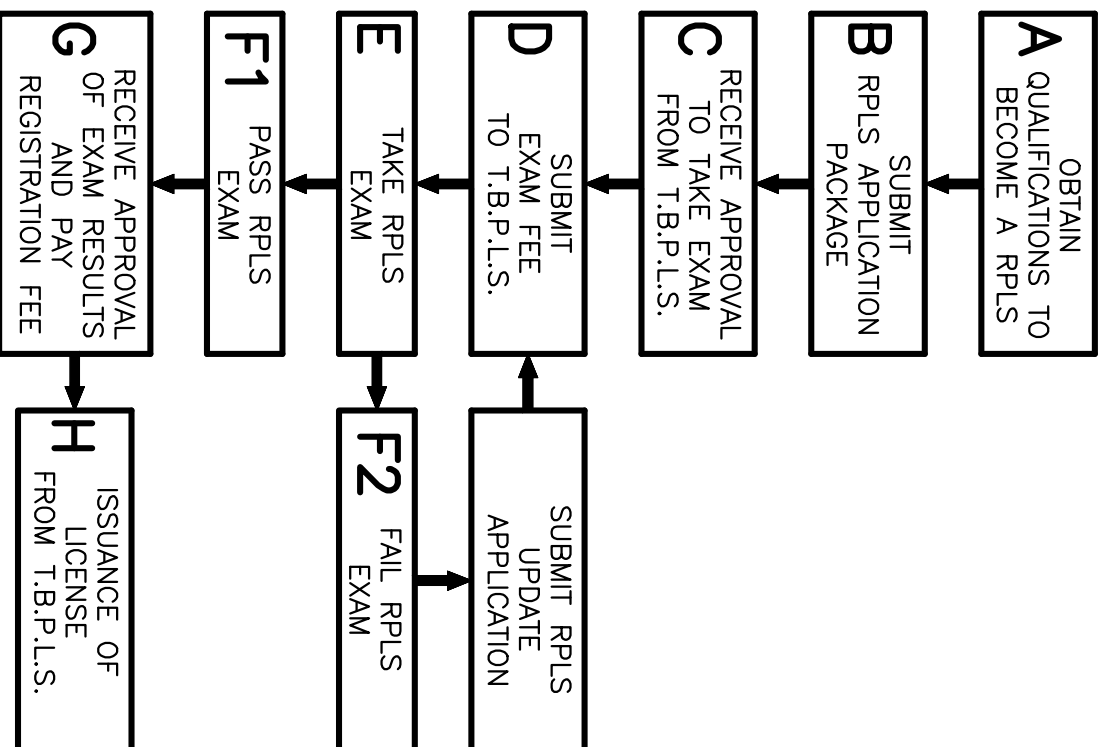

- A. There are three requirements needed to qualify to take the RPLS exam:
1. hold a certificate as a Surveyor in Training
 2. hold a Bachelor of Science in surveying or a Bachelor's degree with 32 hours in civil engineering, land surveying, math, photogrammetry, forestry, land law or the physical sciences;
 3. have a minimum of 2 years experience satisfactory to the T.B.P.L.S. as a Surveyor in Training
- B. Submit the RPLS application package to the T.B.P.L.S. which includes:
1. completed RPLS application form
 2. completed Character, Reputation and Fitness Information form
 3. completed Compliance Verification forms (5)
 4. official college transcripts (unopened)
 5. Survey reports and Documentation Lists (2 ec.)
 6. Verification of Registration Forms (reciprocal applicants only)
 7. required application fee
- C. the T.B.P.L.S. will review the application package to verify qualifications. If approved, the applicant will be instructed to proceed with exam registration.
- D. To register for the exam, applicants must submit the required examination fee.
- E. take the exam at the location and date furnished to you by the T.B.P.L.S.
- F. following the exam, you will be notified by the T.B.P.L.S. of the exam results
If you receive:
1. a passing grade, you will continue to step G.
 2. a failing grade, you may submit an Update Application and fee and return to Step C.
- G. Upon receipt of your passing exam results, you will be instructed to execute and submit the required oath and pay the current registration fee.
- H. You will be issued your license from the T.B.P.L.S. and you will be instructed to obtain a seal to complete the registration process.

NOTE: all forms can be found on the T.B.P.L.S. website www.txls.texas.gov

LSLS Information

An individual interested in licensure as a Licensed State Land Surveyor (LSLS) in the state of Texas must be licensed as a RPLS, be a Texas resident, and pass the LSLS Exam. A LSLS must also sign the oath of office in order to be permitted to practice.

I. Prerequisites

An individual seeking licensure as a LSLS must pass the application process to sit for the LSLS Exam. They must also hold a current license as an RPLS in Texas and submit proof that they reside in Texas. There is no required time period that an individual must hold a RPLS license before they can seek to become an LSLS.

II. Applying to take the LSLS Exam

An applicant must arrange a meeting with the Director of Surveying at the General Land Office prior to starting the application process. This meeting is designed to orient the applicant with the history, function, and contents of the General Land Office and to answer questions regarding the duties and functions of a LSLS.

An applicant must submit the following to complete the application process to take the exam:

- a. Complete each question on the LSLS Application Form. Include with the application a passport-type picture of the applicant (this is required even if you have submitted a picture with the SIT or RPLS application) and a check or money order, made payable to the Texas Board of Professional Land Surveying, in the amount of the required fee.
- b. Submit three LSLS Reference Waiver Forms, at least one of which having been completed by a LSLS.
- c. Submit a working sketch of an area of your choice (preferably in your own county) embracing several surveys and including the work of at least three original locating surveyors. The working sketch must:
 - i. show the complete results of all of the record investigation conducted, not only at the General Land Office but at other sources as well;
 - ii. be accompanied by a preliminary report of your findings. The sketch and report (and supporting papers if necessary) must show the source of all of the information you would assemble prior to going to the field to make a survey of vacancy or excess; and
 - iii. meet the minimum standards set forth by the Board

III. LSLS Exam

a. Exam Contents

The LSLS Exam will cover, but is not limited to, the following subject matter:

- i. The Laws of Land Boundaries – Current, Repealed and Historic
 1. Gammel’s Laws of Texas
 2. Vernon’s Annotated Civil Statutes
 3. Texas Natural Resources Codes
 4. Texas Administrative Code
 5. The Professional Land Surveying Practices Act
 6. TBPLS General Rules of Procedures and Practices
- ii. Authority, duties, and obligations of a LSLS
- iii. History, function, and contents of the General Land Office and its importance to surveying
- iv. Land boundary suits in Texas
- v. Theory of surveying
- vi. Practical surveying
- vii. Theory and use of surveying instruments
- viii. Necessary calculations, including state plane coordinates
- ix. Preparation of field notes
- x. The precedents set up by the courts for surveyors to follow in retracting or re-establishing the lines of surveys

The LSLS exam is a two-part, eight-hour exam offered twice a year. The first four hour session is closed book, while the second session is open book. Examinees will be required to show a current, federal or state issued, photo ID in order to be admitted into the testing area. All LSLS Exams are compiled by the Texas Board of Professional Land Surveying.

b. Exam Results

Examinees are notified of their results by mail within 30 days of the exam.

i. Passing the exam

Examinees that pass the LSLS Exam Committee’s review of their exam materials are awarded a license as a LSLS. At the time that an examinee is notified that they passed the exam they are required to submit the registration fee in order to be issued their license. The new registrant will be required to sign the LSLS Oath and submit it to the Board.

ii. Failing the exam

If the examinee fails the exam they will have two more opportunities to take it before they are required to wait for the period of one year. In order to retake the LSLS Exam, the examinee must submit the LSLS Update Application and exam fee.

This concludes the Candidate Guidelines. All outside documentation mentioned in this document are linked to the Board's website.

If you should have further questions please visit the Board's website at txls.texas.gov or call the Board office at 512) 239-5263.